



EtherDrive® SR1521T

Storage Appliance 3U 15Disk

The Linux Storage People

AoE SAN Storage

Summary

- 15 hot swap SATA disks, AoE accessed as RAID volumes
- Coraid RAID controller provides JBOD or RAID 0,1,5,10 with automatic global spares
- Continuous RAIDShield™ testing fixes SATA disk “soft failures”
- Access speed > 200 MB/sec sustained throughput
- Dual Gigabit Ethernet connections
- Up to 1 TB per SATA disk
- Up to 15 TB per Tower
- Hot swap disks, fans and redundant power supplies
- Simple command line interface
- Syslog status messages
- MAC filtering restricts volume access to authorized servers
- AoE drivers are included in the Linux kernel and available for Windows, Linux, Mac OS X, FreeBSD, and Solaris Operating Systems.
- Coraid open RAID algorithm, your data is not captive to a proprietary RAID controller
- RAID configuration stored on each disk allowing disk portability



Revolutionary Storage Area Networking (SAN)

Coraid's EtherDrive® SR1521T Storage Appliance is a fast and simple alternative to iSCSI and Fibre Channel RAID boxes. EtherDrive® storage uses the open ATA-over-Ethernet (AoE) storage protocol. AoE is a simple way to move storage out of your servers and onto an Ethernet storage network. With AoE, disk read/write requests are placed directly into Ethernet frames. The AoE protocol doesn't need TCP/IP so its easy to process and doesn't require special network interface cards.

EtherDrive® storage is accessible and shared by any server/host machine attached to the storage network. Disks inside the storage appliance are assembled into RAID volumes and presented as AoE block storage devices. Servers discover and mount AoE storage devices by using an AoE software driver. The AoE driver presents an AoE device, to the host OS, as a local disk drive. AoE storage is fast and can be used like any other disk drive.

Unlimited Storage

Users save money by installing their own disk drives. The SR1521T storage appliance accepts any standard SATA or SATA2 disk. As disk capacity increases, higher density disks can be installed quickly and easily.

There are no limits to how many disks can be attached to a server. There are no constraints to how big an AoE storage network can be expanded. Each time a new EtherDrive® Storage Appliance is added to the storage network, more processing power is added and therefore aggregate throughput and IOPS performance of the storage system is also increased.



EtherDrive® SR1521T

Storage Platform 3U 15Disk

The Linux Storage People



Free Standing Tower - 15 Slot Shelf

Everything is included, all you need to add are SATA disks. Each EtherDrive® SR1521T combines up to 15 SATA disks into RAID volumes then connects them to the AoE storage network. AoE storage appears as a local disk drive to its host.

Simple to Understand, Simple to Manage

The simplicity of EtherDrive® Storage makes it easy to manage, because it's easy to understand. EtherDrive® Storage is a disk connected to your server via Ethernet. That disk may actually be a RAID volume, but it just looks like a big disk to the user. No need to learn complicated technology like Fibre Channel. Just add SATA disks to the EtherDrive® Storage Appliance and you have all the space you want on any server attached to the AoE storage network. It's that simple.

Low Cost Networked Storage

EtherDrive® Storage is less expensive than any other networked storage. The storage costs for traditional Storage Area Networks (SANs) are very high. Fibre Channel switches and Host Bus Adapter (HBA) interfaces are expensive, take up a lot of space, and require costly system administration. EtherDrive® Storage eliminates all that by being a very simple and affordable.

Easy to Install, Easy to Grow

A simple command line interface allows you to create disk RAID volumes. JBOD and RAID levels 0, 1, 5, 10 can be used. You can also expand a RAID set by concatenating RAID sets. You can assign hot spare disks that will automatically backup a failed disk. Alarm and status messages are used to update the host's syslog.

Performance and Reliability You Want

With the SR1521T, sustained storage access speed of over 200 MBytes/sec can be achieved. And since the AoE protocol is simple, the host processing load is minimized. Multiple GigE interfaces also provide redundancy for the network connection.

Advanced RAID Controller

The SR1521T uses Coraid's RAIDShield™ algorithm to continuously test each disk in a RAID volume. RAIDShield™ is able to detect and repair disk "soft failures" before the user discovers them. Soft failures are bad blocks on the disk media that can be re-mapped by the disk itself to spare block locations. This means you won't be prematurely replacing perfectly good disks that were rejected by a typical RAID controller card when it tries to access one of these soft failed block locations.

Coraid's RAID controller marks each disk with its RAID configuration information. Disk in the chassis have no locational dependency, and can be moved between slots or between chassis without losing the RAID configuration or the users data. This makes maintenance easy if you ever need to replace an entire SR1521T chassis.

Coraid's RAID algorithm is open and published as part of AoE tools on sourceforge.net. Your data is never captive to a proprietary RAID controller. In an emergency RAID volumes can be unraveled and data recovered one disk at a time using any Linux host. Isn't that comforting to know?

EtherDrive® Storage Security

MAC address filtering allows the storage appliance to restrict access to volumes based upon host MAC addresses. With MAC address filtering, only hosts with allowed MAC addresses can access specified logical volumes within the SR1521T.

Simple Network Connection

EtherDrive® Storage is block storage just like a hard disk drive, but located on the network. A software driver in the host discovers AoE storage on its network connections. Discovery is performed periodically by the software driver. AoE devices are presented as standard block devices to the host OS. On Linux hosts AoE devices show up in the /dev directory as etherd/x.x. On Windows hosts, the driver presents an AoE device as a hard disk in the Windows device manager, once formatted it becomes a “letter” drive.

AoE devices can be formatted (or partitioned and formatted) with any filesystem (ie. EXT3, NTFS, FAT32, XFS, JFS, GFS, etc.). If the AoE volume is to be simultaneously shared by more than one host, a “cluster filesystem” like GFS must be used.

AoE devices are not natively Network Attached Storage (NAS) devices, but they can be used with a NAS Gateway server that provides NFS (or SMB/CIFS) “File” level sharing. Coraid’s CLN21 NAS Gateway is an example of a Linux server providing file sharing services using an unlimited pool of AoE storage devices.

Servers can attach directly to EtherDrive storage using standard CAT6 GigE cables (auto-polarity sensing is provided by the SR1521T) or by connection to a Gigabit Ethernet switch. A separate dedicated AoE SAN is highly recommended and for best performance the network and host NICs should support jumbo Ethernet frames.

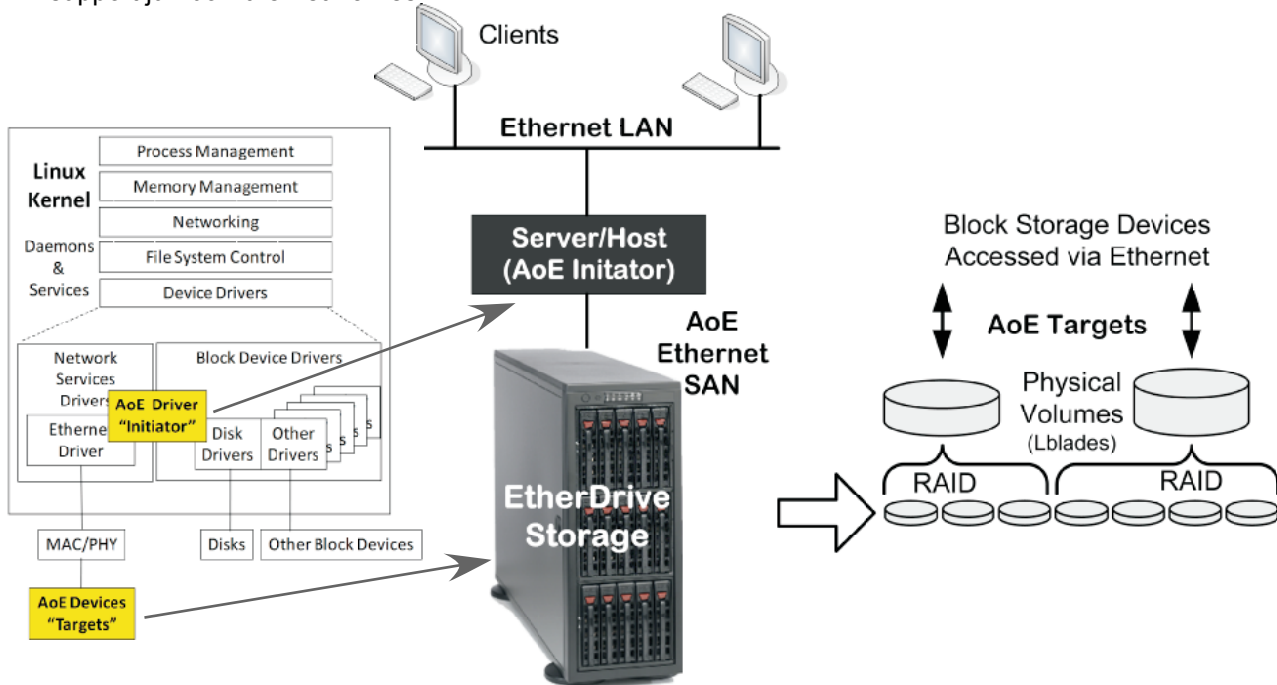

AoE eliminates unnecessary protocol layers. That makes AoE simple and fast.

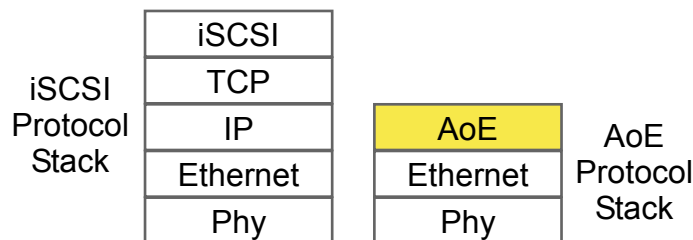

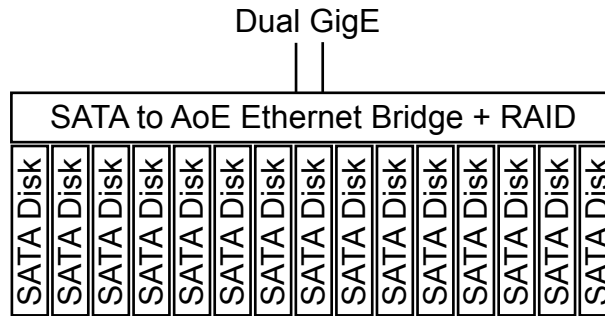

Specifications

3.5" SATA Disk Capacity	any size, up to 1TB SATA1 or SATA2 drive, hot swap
Control Interface	RS-232, KVM or EtherConsole, command line interface
Network Interface	Dual 1 Gigabit/sec Ethernet, RJ-45
Number of simultaneous hosts accessing storage	No limit
Storage Access Speed	> 90,000 IOPS, >200MBytes/sec with jumbo frames
RAID Types Supported	RAID 0 (striping) RAID 1 (mirroring) RAID 5 (striping with parity) RAID10 (striping with mirror) JBOD (just a bunch of individual disks)
Storage Security (optional)	MAC address filtering, only allowed MAC addresses can access specified logical blades
Power Supply	100-240 VAC, 50/60Hz Redundant hot swap power modules
Cooling	4 hot swap fans
Power Consumption with disk drive	< 400 Watts, heat load < 1500 BTU
Shelf Dimensions	H 17.6 x W 7 x D 26.5 inches, 75 lbs with disks
SATA Disk Drives per Shelf	15
Shelf Capacity	Up to 15 TeraBytes
Expansion	up to 65,536 shelves per network (983,040 disks)
Operating Temp	50-95 degrees F (10-35 degrees C)
Relative Humidity	20%to 90%(non-condensing)
Warranty	36 Month
Operating System	AoE is in the Linux 2.6.11+ kernel, drivers for earlier Linux kernels are available from Coraid, Drivers are also available for FreeBSD, Solaris, Apple OS X and Windows.

For information on EtherDrive® Storage, call +1-706-548-7200, email info@coraid.com or visit our web site www.coraid.com